

# **QT-Brightek Metal Can Series**

## **TO-46 Package**

**Part No.: LED55X LED56**

**X=B or C**

Product: LED55X LED56 series	Date: September 20, 2018	Page 1 of 7
Preliminary	Version# 1.1	



---

**Table of Contents**

Introduction ..... 3  
Electrical / Optical Characteristic (T=25 °C) ..... 4  
Absolute Maximum Rating ..... 4  
Characteristic Curves..... 5  
Packing ..... 6  
Ordering Information ..... 6  
Revision History ..... 7  
Disclaimer ..... 7

Product: LED55X LED56 series	Date: September 20, 2018	Page 2 of 7
Preliminary	Version# 1.1	

## Introduction

**Feature:**

- TO-46 Package
- Narrow viewing angle: 16°
- Enhanced temperature range
- GaAs

**Description:**

This infrared emitter is designed for applications requiring high output.

**Application:**

- Infrared applied system
- Optoelectronic switch
- Sensing system

**Certification & Compliance:**

- TS16949
- ISO9001
- RoHS Compliant



**Dimension:**

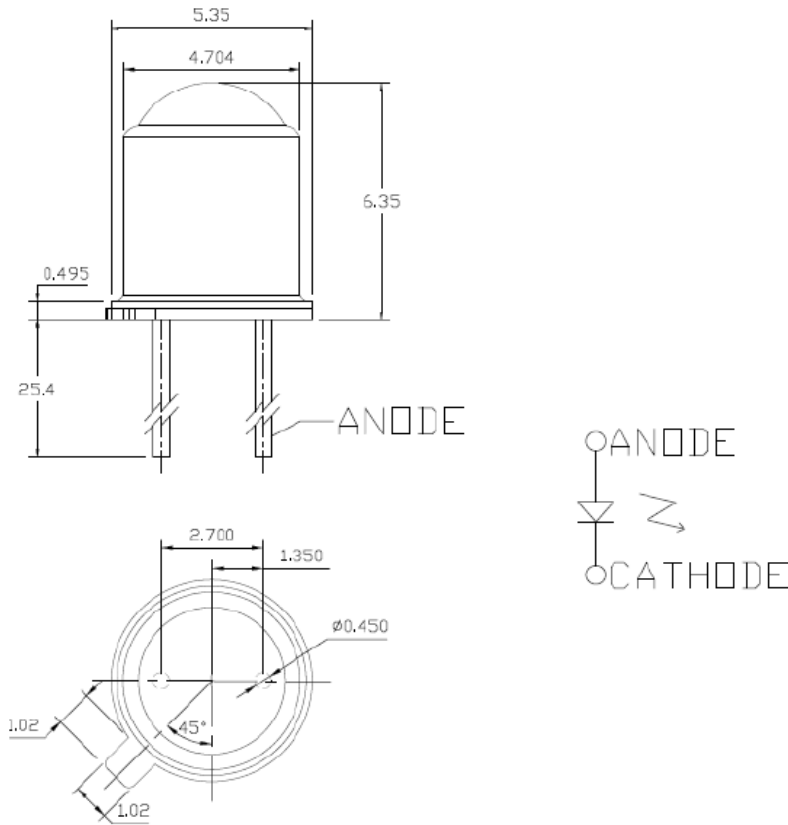

Units: mm / tolerance = +/-0.25mm

**Electrical / Optical Characteristic (T=25 °C)**

Parameter	Symbol	Output			Units	Test Conditions
		Min	Typ	Max		
Total Power LED55B	P <sub>O</sub>	3.5	--	--	mW	I <sub>F</sub> =100mA
Total Power LED55C	P <sub>O</sub>	5.4	--	--	mW	I <sub>F</sub> =100mA
Total Power LED56	P <sub>O</sub>	1.5	--	--	mW	I <sub>F</sub> =100mA
Peak Wavelength	λ <sub>P</sub>	--	940	--	nm	I <sub>F</sub> =100mA
Forward Voltage	V <sub>F</sub>	--	--	1.8	V	I <sub>F</sub> =100mA
Reverse Current	I <sub>R</sub>	--	--	10	μA	V <sub>R</sub> =3V
Viewing Angle	2 θ <sub>1/2</sub>	-	16	-	deg	I <sub>F</sub> =100mA
Rise time	t <sub>r</sub>	-	1.0	-	μS	-
Fall time	t <sub>f</sub>	-	1.0	-	μS	-

**Absolute Maximum Rating**

Material	P <sub>d</sub> (mW)	I <sub>F</sub> (mA)	I <sub>FP</sub> * (A)	V <sub>R</sub> (V)	T <sub>OP</sub> (°C)	T <sub>ST</sub> (°C)
GaAs	180	100	10	5	-65 to + 125	-65 to +150

\*pw, 1us; 200Hz

\*\* Soldering for no more than 10 sec @ 260 °C

**Characteristic Curves**

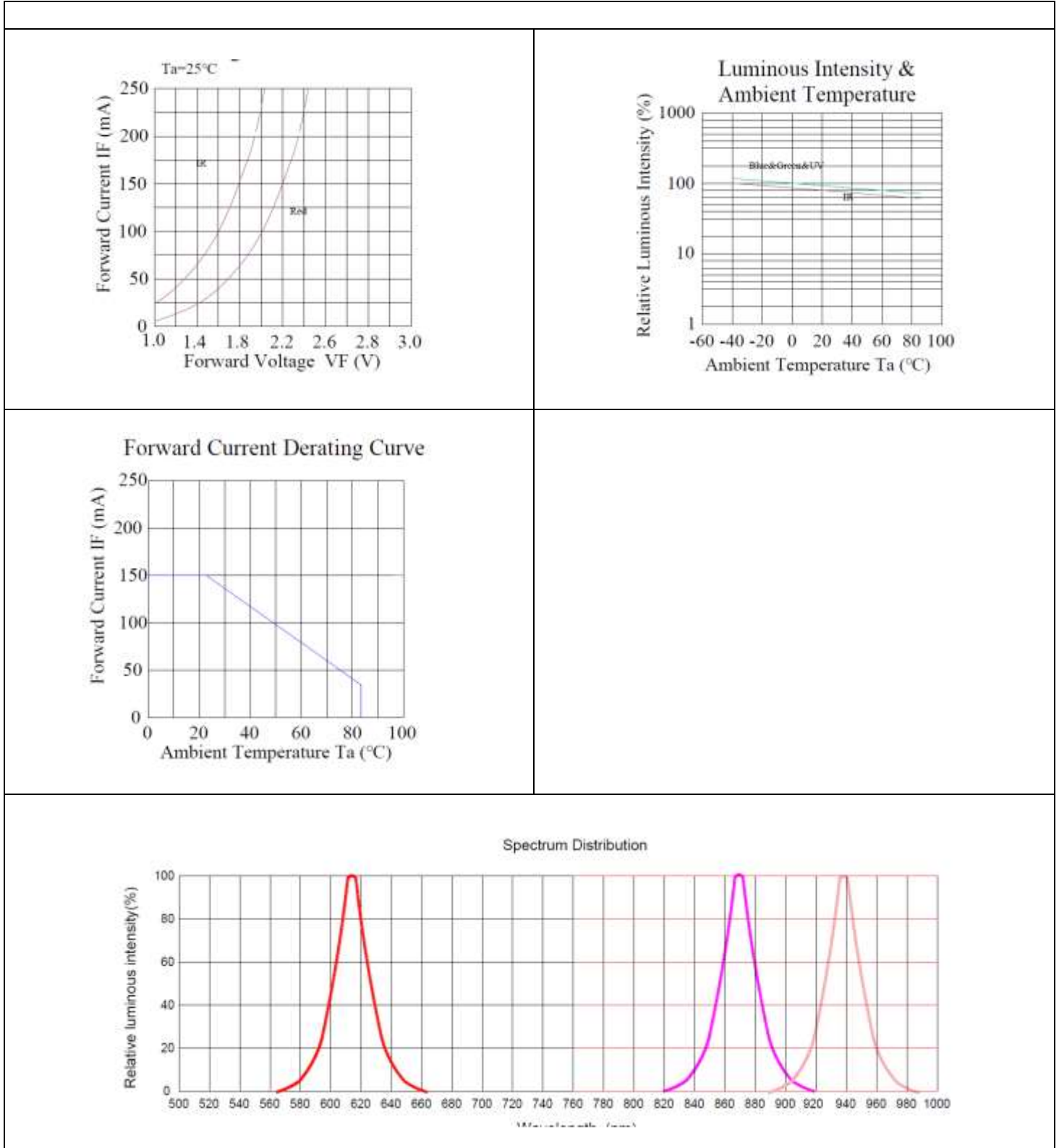

---

## Packing

Packaging Specifications: TBD

## Ordering Information

Part #	Orderable Part #	Spec Range	Quantity per bag
LED55B	LED55B	Po=3.5mW @ IF=100mA	--
LED55C	LED55C	Po=5.4mW @ IF=100mA	--
LED56	LED56	Po=1.5mW @ IF=100mA	--



## Revision History

Description:	Revision #	Revision Date
New Release of LED55X LED56 series	V1.0	12/12/2016
Amend Graph	V1.1	09/20/2018

## Disclaimer

QT-BRIGHTTEK reserves the right to make changes without further notice to any products herein to improve reliability, function or design. QT-BRIGHTTEK does not assume any liability arising out of the application or use of any product or circuit described herein; neither does it convey any license under its patent rights, nor the rights of others.

## Life Support Policy

QT-BRIGHTTEK's products are not authorized for use as critical components in life support devices or systems without the express written approval of QT-BRIGHTTEK. As used herein:

1. Life support devices or systems are devices or systems which, (a) are intended for surgical implant into the body, or (b) support or sustain life, and (c) whose failure to perform when properly used in accordance with instructions for use provided in the labeling, can be reasonably expected to result in a significant injury of the user.
2. A critical component in any component of a life support device or system whose failure to perform can be reasonably expected to cause the failure of the life support device or system, or to affect its safety or effectiveness.

Product: LED55X LED56 series	Date: September 20, 2018	Page 7 of 7
Preliminary	Version# 1.1	