

# **QT-Brightek Chip LED Series**

## **SMD 0603 LED**

**Part No.: QBLP601L series**

L=Low Profile

---

**Table of Contents:**

Introduction .....	3
Electrical / Optical Characteristic (Ta=25 °C) .....	4
Absolute Maximum Rating .....	4
CIE Chromaticity Diagram.....	7
Solder Profile & Footprint.....	10
Packing .....	11
Labeling .....	12
Ordering Information .....	12
Revision History .....	13
Disclaimer .....	13

## Introduction

### Feature:

- Yellow Diffused Lens for White
- Water clear lens for all colors except white
- Package in tape and reel
- Ultra bright 0603 LED package
- InGaN technology for IB/IG
- AlInGaP technology for R/S/AG/Y/O
- VA=150deg

### Description:

These ultra bright 0603 LEDs have a height profile of 0.40mm. Combination of high brightness output and small footprint, these LEDs are ideal for keypad backlighting and status indication.

### Application:

- Status indication
- Back lighting application

### Certification & Compliance:

- TS16949
- ISO9001
- RoHS Compliant



### Dimension:

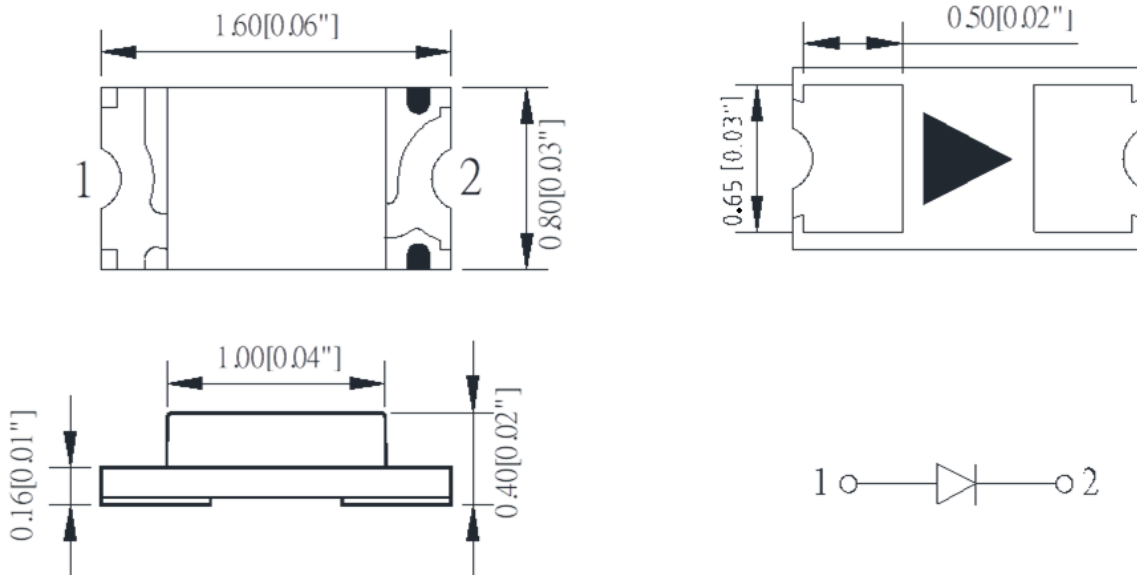

Units: mm / tolerance = +/-0.1mm

### Electrical / Optical Characteristic (Ta=25 °C)

Product	Color	I <sub>F</sub> (mA)	V <sub>F</sub> (V)		λ <sub>D</sub> (nm)			I <sub>V</sub> (mcd)	
			Typ.	Max.	Min.	Typ.	Max.	Min.	Typ.
QBLP601L-IB	Blue	20	3.2	3.7	465	470	475	80	100
QBLP601L-IG	True Green	20	3.2	3.7	520	525	530	250	450
QBLP601L-R	Red	20	2.0	2.5	620	625	630	50	80
QBLP601L-S	Deep Red	20	2.0	2.5	630	640	650	32	50
QBLP601L-AG	Yellow Green	20	2.0	2.5	565	570	576	20	40
QBLP601L-Y	Yellow	20	2.0	2.5	585	590	595	50	85
QBLP601L-O	Orange	20	2.0	2.5	600	605	610	50	95
					<b>Chromaticity Coordinates</b>				
					<b>Min.</b>	<b>Typ.</b>	<b>Max.</b>		
QBLP601L-IW-CW	Cool White	20	3.2	3.7	-	0.29,0.28	-	125	200

### Absolute Maximum Rating

Material	P <sub>d</sub> (mW)	I <sub>F</sub> (mA)	I <sub>FP</sub> (mA)*	V <sub>R</sub> (V)	T <sub>OP</sub> (°C)	T <sub>ST</sub> (°C)	T <sub>SOL</sub> (°C)**
InGaP (IB/IG/IW)	111	30	125	5	-40 ~ +80	-40 ~ +100	260
AllnGaP (R/S/AG/Y/O)	75	30	125	5	-40 ~ +80	-40 ~ +100	260

\*Duty 1/8 @ 1KHz

\*\*IR Reflow for no more than 10 sec @ 260 °C

### Forward Voltage V<sub>F</sub> For AllnGaP @ I<sub>F</sub>=20mA

Bin	Min.	Max.	Unit
□	1.7	2.5	V

### Forward Voltage V<sub>F</sub> For InGaP @ I<sub>F</sub>=20mA

Bin	Min.	Max.	Unit
F	2.8	3.1	V
g	3.1	3.4	
h	3.4	3.7	

**Luminous Intensity  $I_V$  @  $I_F=20mA$** 

Bin	Min.	Max.	Unit
C	20	25	mcd
D	25	32	
E	32	40	
F	40	50	
G	50	63	
H	63	80	
I	80	100	
J	100	125	
K	125	160	
L	160	200	
M	200	250	
N	250	320	
O	320	400	
P	400	500	
Q	500	630	
R	630	800	

**Dominant Wavelength  $\lambda_D$  for Blue @  $I_F=20mA$** 

Bin	Min.	Max.	Unit
G	465	467.5	nm
H	467.5	470	
I	470	472.5	
J	472.5	475	

**Dominant Wavelength  $\lambda_D$  for True Green @  $I_F=20mA$** 

Bin	Min.	Max.	Unit
U	520	522.5	nm
V	522.5	525	
W	525	527.5	
X	527.5	530	

**Dominant Wavelength  $\lambda_D$  for Red @  $I_F=20mA$** 

Bin	Min.	Max.	Unit
t	620	625	nm
u	625	630	

**Dominant Wavelength  $\lambda_D$  for Deep Red @  $I_F=20mA$** 

Bin	Min.	Max.	Unit
v	630	635	nm
w	635	650	

**Dominant Wavelength  $\lambda_D$  for Yellow Green @  $I_F=20mA$**

Bin	Min.	Max.	Unit
h	565	568	nm
i	568	572	
j	572	576	

**Dominant Wavelength  $\lambda_D$  for Yellow @  $I_F=20mA$**

Bin	Min.	Max.	Unit
m	585	590	nm
n	590	595	

**Dominant Wavelength  $\lambda_D$  for Orange @  $I_F=20mA$**

Bin	Min.	Max.	Unit
p	600	605	nm
q	605	610	

### CIE Chromaticity Diagram

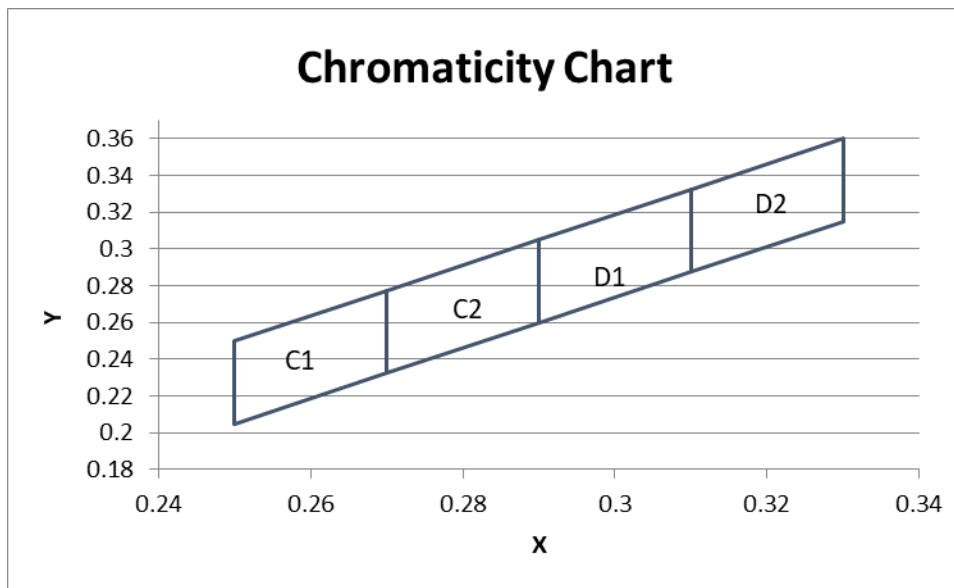

C1		C2		D1		D2	
0.25	0.25	0.27	0.2775	0.29	0.305	0.31	0.3325
0.27	0.2775	0.29	0.305	0.31	0.3325	0.33	0.36
0.27	0.2325	0.29	0.26	0.31	0.2875	0.33	0.315
0.25	0.205	0.27	0.2325	0.29	0.26	0.31	0.2875
0.25	0.25	0.27	0.2775	0.29	0.305	0.31	0.3325

## Characteristic Curves

AllnGaP (R/S/AG/Y/O)

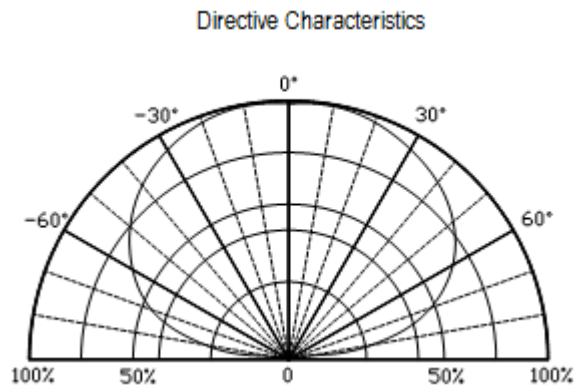
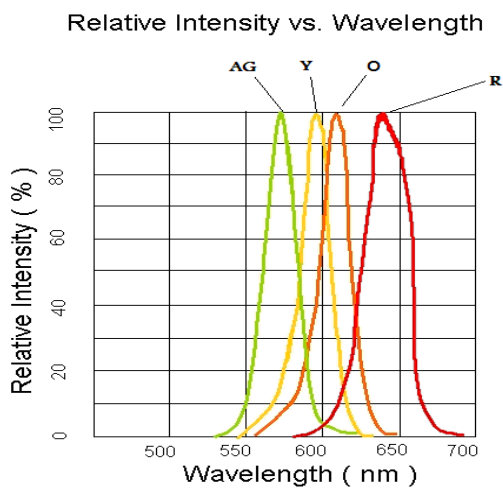
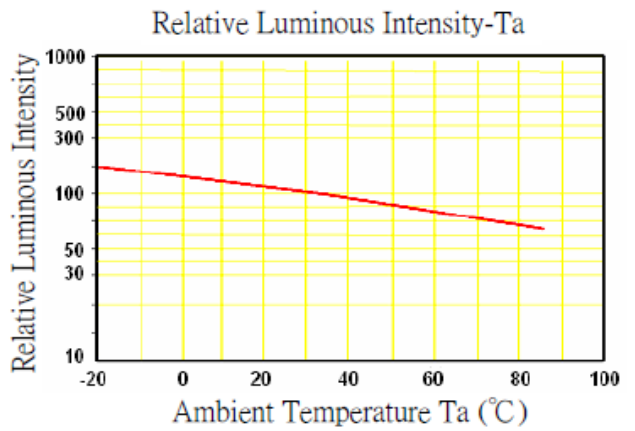
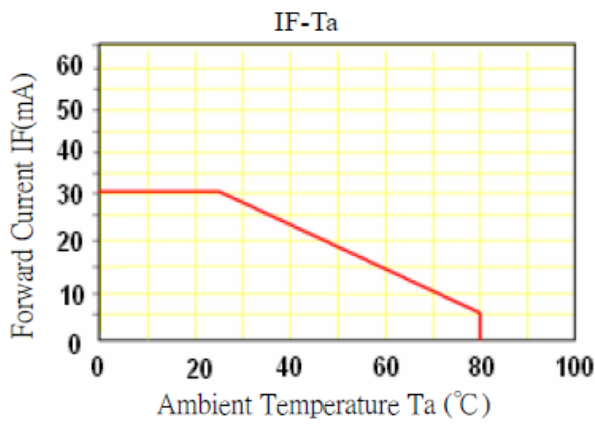
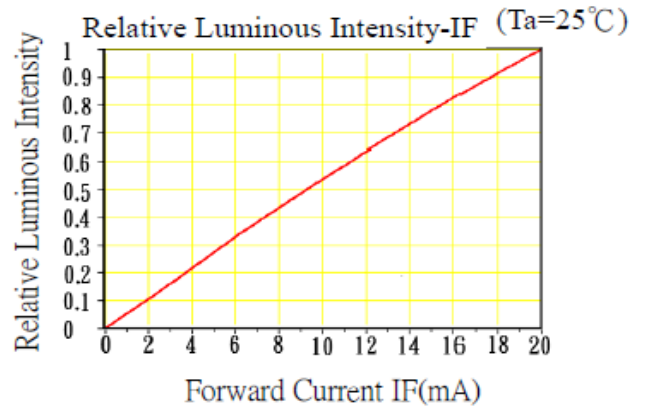
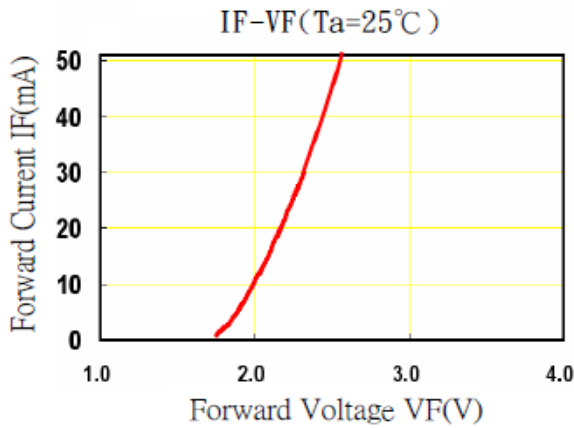



InGaN (IB/IG/ IW)

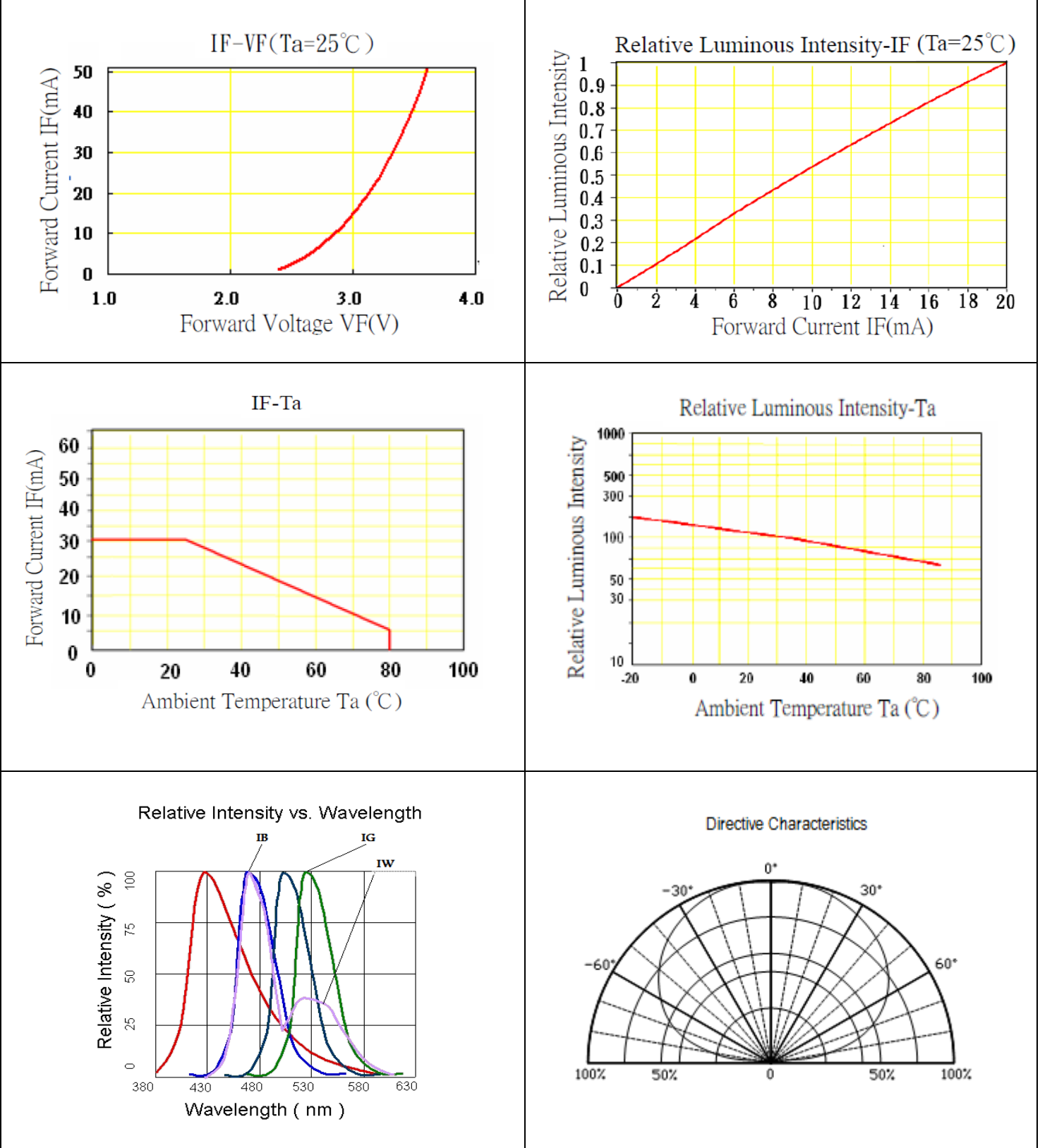

**Solder Profile & Footprint**

- Recommended tin solder specifications: melting temperature in the range of 178~192 °C
- The recommended reflow soldering profile is as follows (temperatures indicated are as measured on the surface of the LED resin):

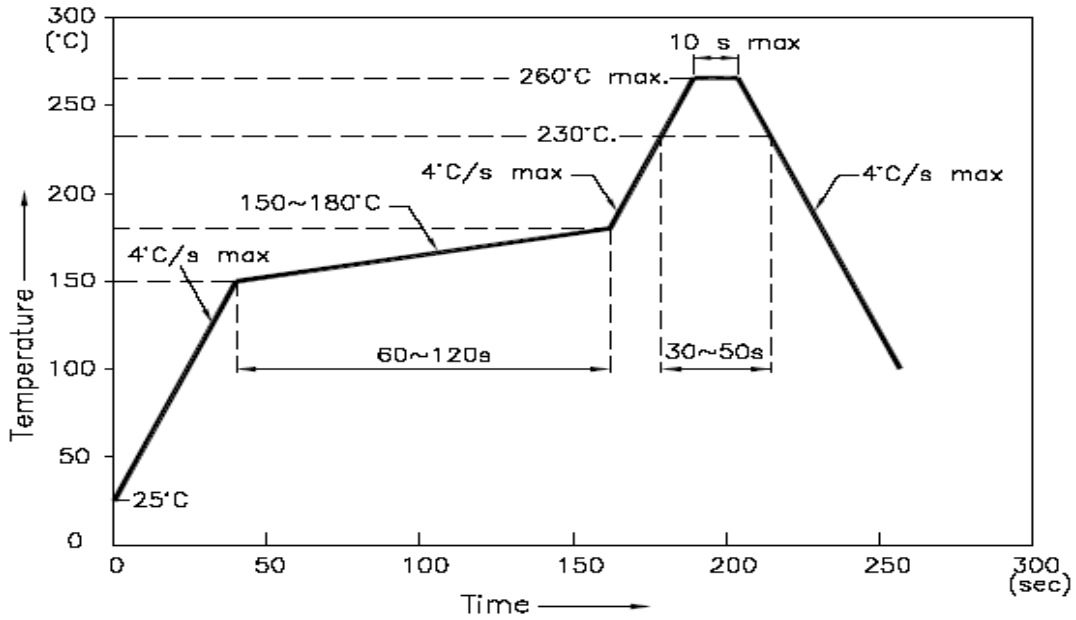

**Recommended Pad Layout**

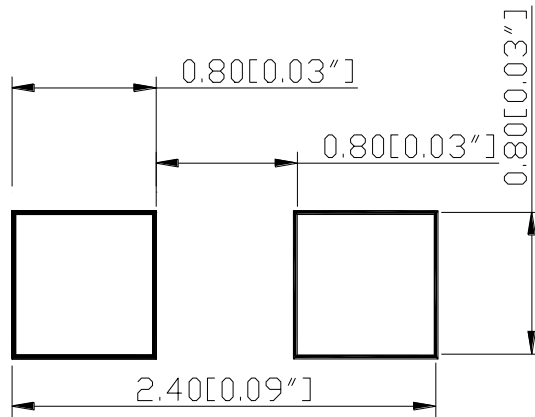

Units: mm

Tolerance: ± 0.1mm

Product: QBLP601L series	Date: November 22, 2019	Page 10 of 13
	Version# 1.0	

## Packing

### Reel Dimension:

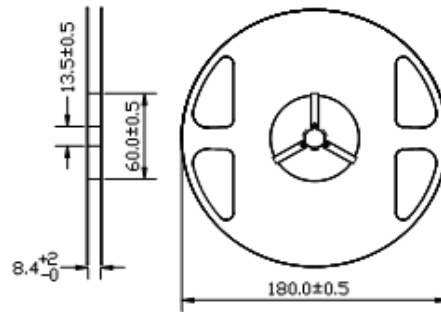

Unit: mm

### Tape Dimension:

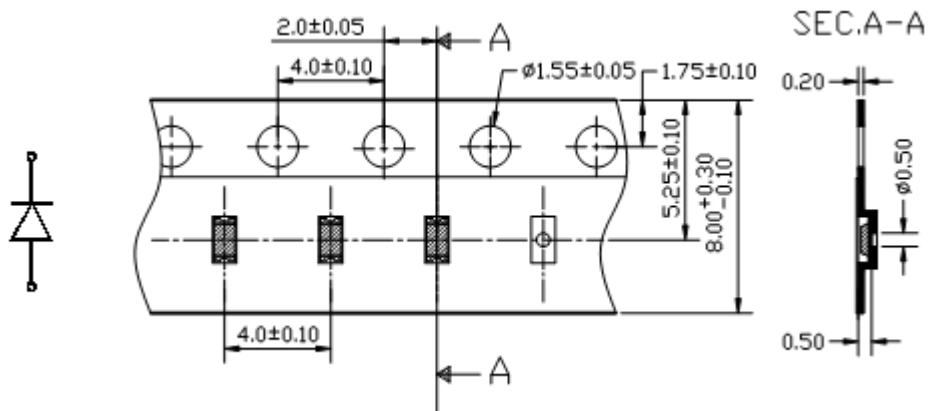

Unit: mm

### Arrangement of Tape:

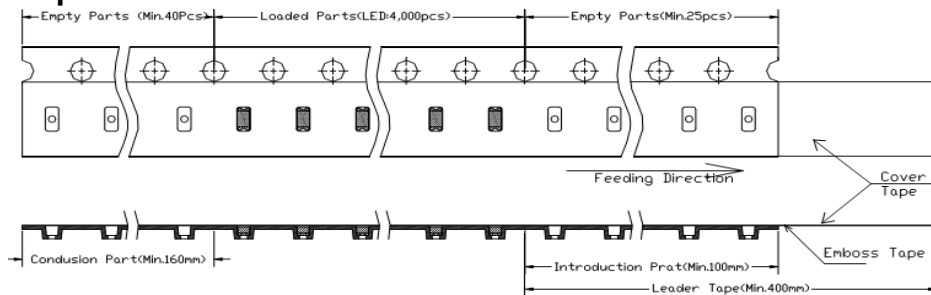

## Packaging Specifications:

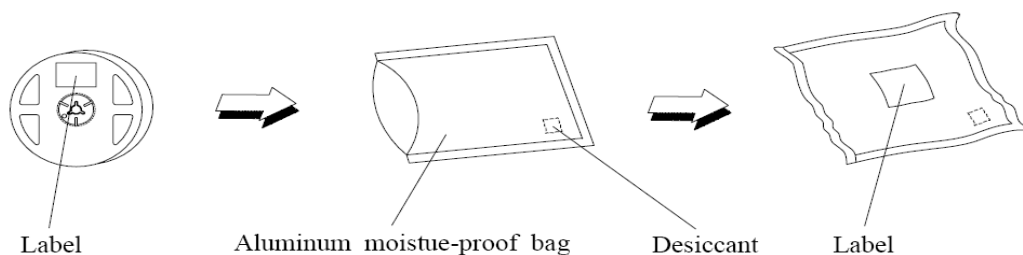

## Labeling



**Part No:** \_\_\_\_\_  
**Customer P/N:** \_\_\_\_\_  
**Item:** \_\_\_\_\_  
**Q'ty:** \_\_\_\_\_  
**Vf:** \_\_\_\_\_  
**Iv:** \_\_\_\_\_  
**WI:** \_\_\_\_\_  
**Date:** \_\_\_\_\_

**Made in China**

## Ordering Information

Part #	Orderable Part #	Spec Range	Quantity per reel
QBLP601L-IB	QBLP601L-IB	Iv=100mcd Typ. @ I <sub>F</sub> =20mA / Color=465nm-475nm	4,000 units
QBLP601L-IG	QBLP601L-IG	Iv=450mcd Typ. @ I <sub>F</sub> =20mA / Color=520nm-530nm	4,000 units
QBLP601L-R	QBLP601L-R	Iv=80mcd Typ. @ I <sub>F</sub> =20mA / Color=620nm-630nm	4,000 units
QBLP601L-S	QBLP601L-S	Iv=50mcd Typ. @ I <sub>F</sub> =20mA / Color=630nm-635nm	4,000 units
QBLP601L-AG	QBLP601L-AG	Iv=40mcd Typ. @ I <sub>F</sub> =20mA / Color=565nm-576nm	4,000 units
QBLP601L-Y	QBLP601L-Y	Iv=85mcd Typ. @ I <sub>F</sub> =20mA / Color=585nm-595nm	4,000 units
QBLP601L-O	QBLP601L-O	Iv=95mcd Typ. @ I <sub>F</sub> =20mA / Color=600nm-610nm	4,000 units
QBLP601L-IW-CW	QBLP601L-IW-CW	Iv=200mcd Typ. @ I <sub>F</sub> =20mA / CCT: (X=0.29, Y=0.28) typ.	4,000 units

**Revision History**

Description:	Revision #	Revision Date
New Release of QBLP601L series	V1.0	11/22/2019

**Disclaimer**

QT-BRIGHTTEK reserves the right to make changes without further notice to any products herein to improve reliability, function or design. QT-BRIGHTTEK does not assume any liability arising out of the application or use of any product or circuit described herein; neither does it convey any license under its patent rights, nor the rights of others.

**Life Support Policy**

QT-BRIGHTTEK's products are not authorized for use as critical components in life support devices or systems without the express written approval of QT-BRIGHTTEK. As used herein:

1. Life support devices or systems are devices or systems which, (a) are intended for surgical implant into the body, or (b) support or sustain life, and (c) whose failure to perform when properly used in accordance with instructions for use provided in the labeling, can be reasonably expected to result in a significant injury of the user.
2. A critical component in any component of a life support device or system whose failure to perform can be reasonably expected to cause the failure of the life support device or system, or to affect its safety or effectiveness.