

QT-Brightek PLCC Series

3020 PLCC-2 VCSEL

Part No.: QBLP676E-VXXXA
XXX = 680nm, 850nm, or 940nm

Table of Contents:

Introduction	3
Electrical / Optical Characteristic (Ta=25 °C)	4
Absolute Maximum Rating	4
Characteristic Curves.....	5
Solder Profile & Footprint.....	6
Packing	7
Labeling	8
Ordering Information	8
Revision History	9
Disclaimer	9

Introduction

Feature:

- Water clear lens
- Package in tape and reel
- Ultra bright reflector type 3020 LED
- VCSEL 680nm, 850nm & 940nm
- ESD protection
- 680nm: Viewing Angles 25 Degree
- 850nm: Viewing Angles 36 Degree
- 940nm: Viewing Angles 18 Degree

Description:

This 3020 VCSEL has a height profile of 1.30mm. Combination of high brightness output and robust package, this device is ideal for Infrared Sensor, medical device and consumer electronic application.

Application:

- Infrared Sensor
- Medical device
- Consumer electronics

Certification & Compliance:

- TS16949
- ISO9001
- RoHS Compliant



Dimension:

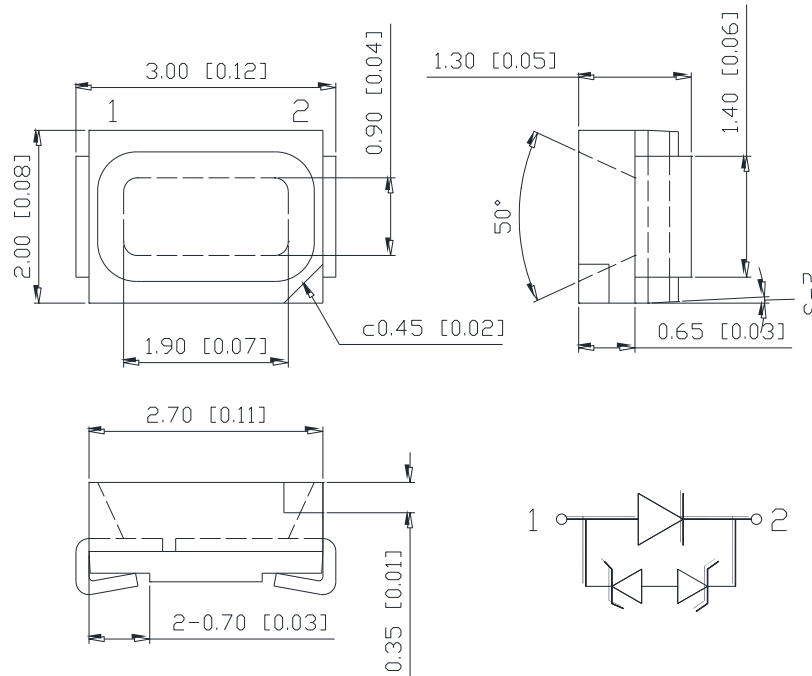

Units: mm / tolerance = +/-0.2mm

Electrical / Optical Characteristic (Ta=25 °C)

Product	Color	I _F (mA)	V _F (V)		λ _P (nm)			P _O (mW)	
			Typ.	Max.	Min.	Typ.	Max.	Min.	Typ.
QBLP676E-V680A	Infrared	9	2.4	2.8	670	680	690	2.5	4
QBLP676E-V850A	Infrared	9	2.4	2.8	840	850	860	3	4.5
QBLP676E-V940A	Infrared	9	1.9	2.1	930	940	950	4.5	6

Absolute Maximum Rating

λ _P (nm)	I _F (mA)	I _{PF} (mA)*	I _r (uA) @ V _R =5V	T _{OP} (°C)	T _{ST} (°C)	T _{SOL} (°C)**
680	9	12	1	-20 ~ +70	-40 ~ +85	260
850	12	-	1	-20 ~ +85	-40 ~ +85	260
940	12	-	1	-20 ~ +85	-40 ~ +85	260

*≤1us pulse width, 1% Duty Cycle

** IR Reflow for no more than 10 sec @ 260 °C

Note:

Tolerance of measurement of forward voltage: ±0.1V

Tolerance of measurement of output power: ±15%

Tolerance of measurement of peak wavelength: ±2nm

Characteristic Curves

VCSEL 680nm

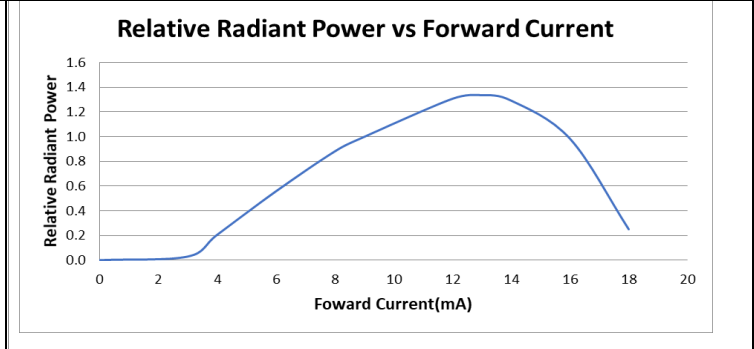
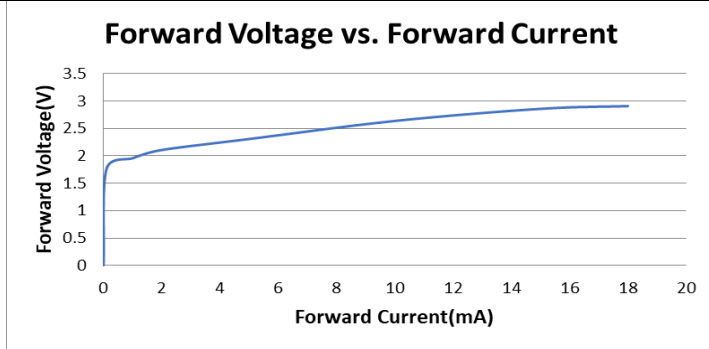

VCSEL 850nm

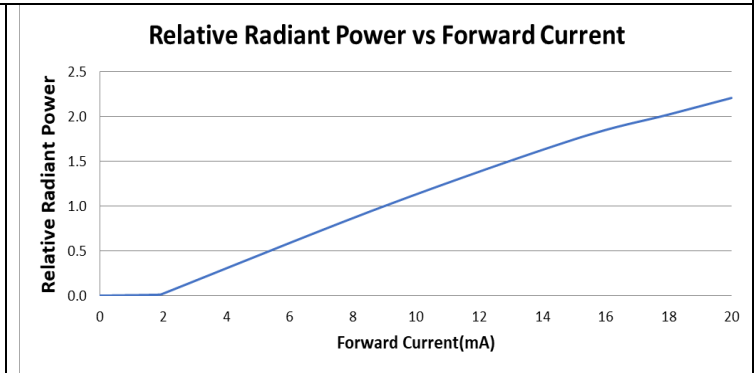
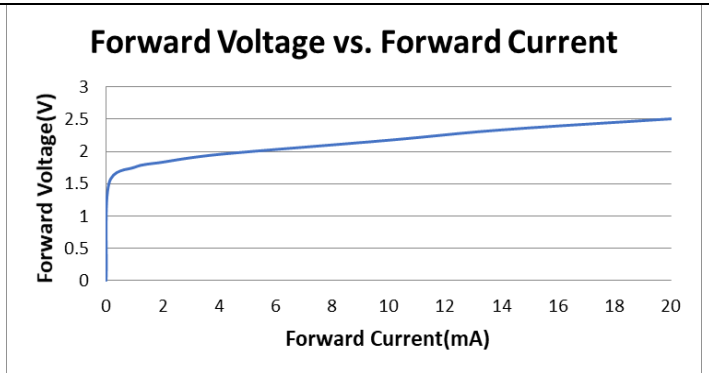

VCSEL 940nm

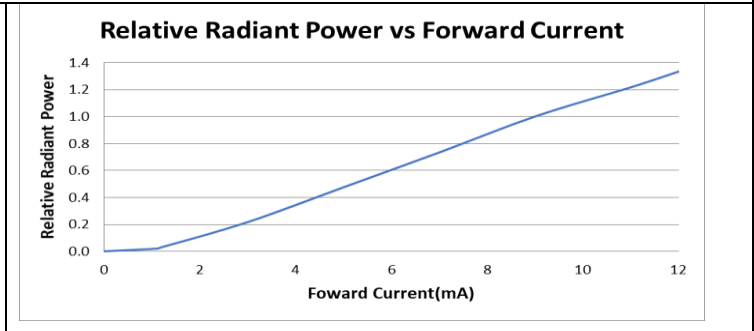
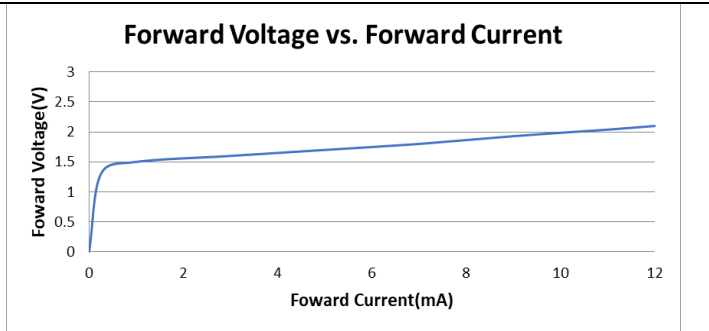

Solder Profile & Footprint

- Recommended tin solder specifications: melting temperature in the range of 178~192 °C
- The recommended reflow soldering profile is as follows (temperatures indicated are as measured on the surface of the LED resin):

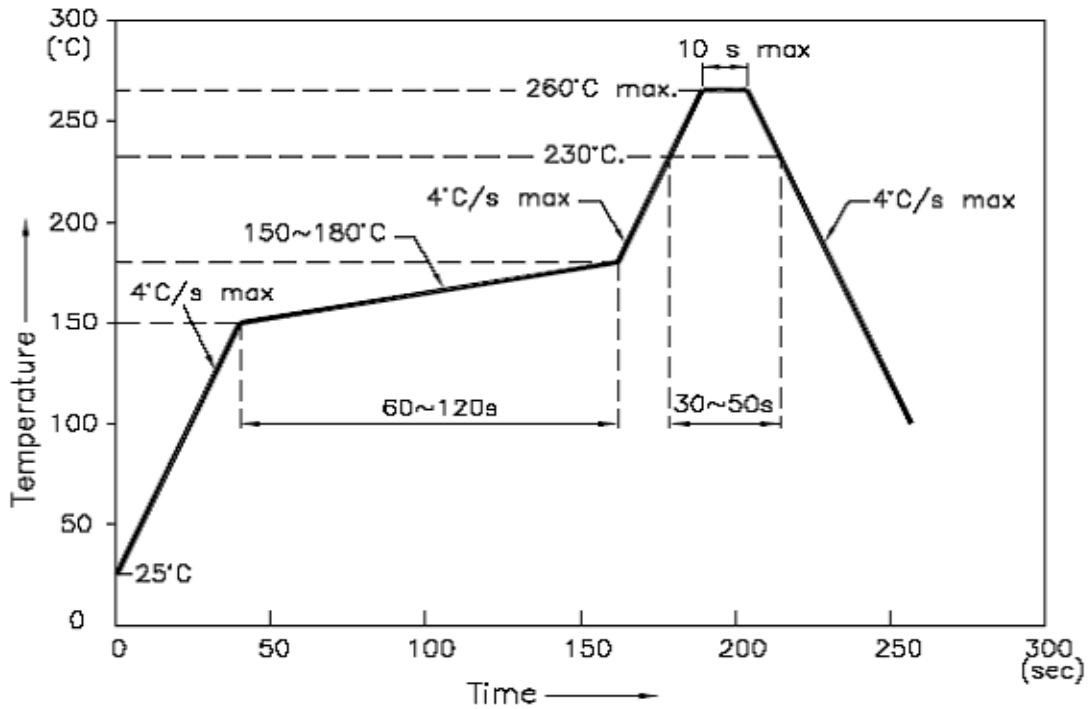

Recommended Pad Layout

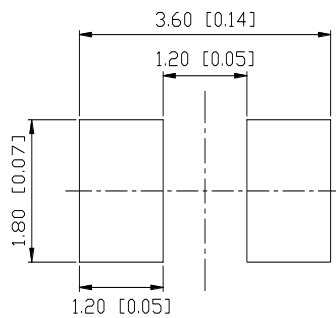

Units: mm

Tolerance: ± 0.2mm

Packing

Reel Dimension:

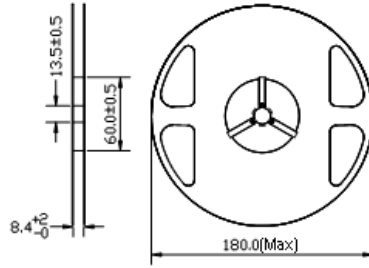

Unit: mm

Tape Dimension:

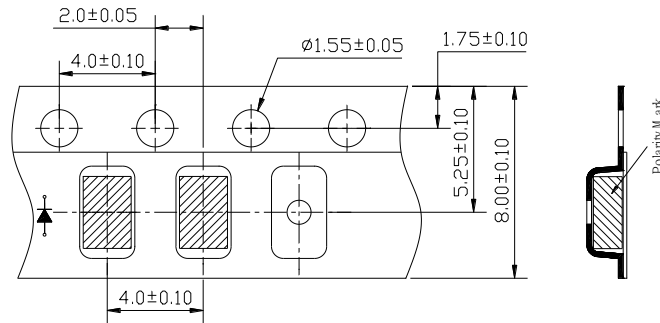

Unit: mm

Packaging Specifications:

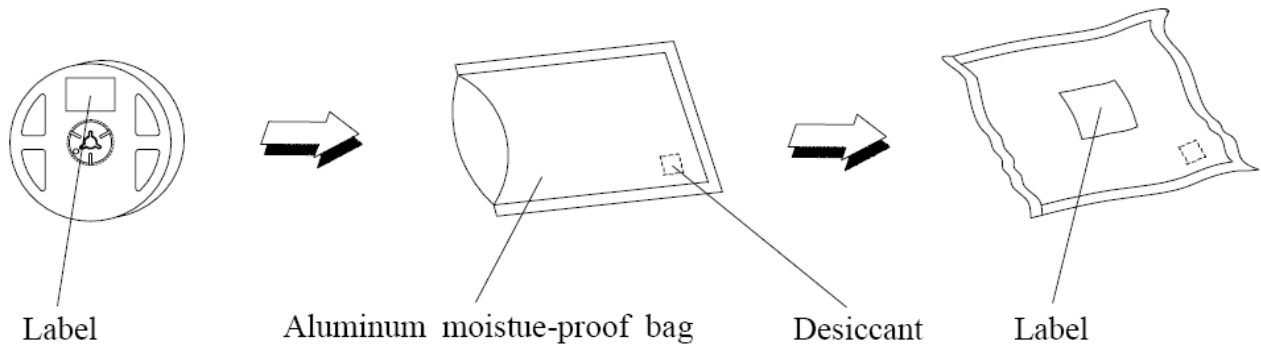

Labeling**Part No:** _____**Customer P/N:** _____**Item:** _____**Q'ty:** _____**Vf:** _____**Iv:** _____**WI:** _____**Date:** _____**Made in China****Ordering Information**

Part #	Orderable Part #	Spec Range	Quantity per reel
QBLP676E-V680A	QBLP676E-V680A	Po=4 typ. mW @ 9mA / WLP=680nm	3,000 units
QBLP676E-V850A	QBLP676E-V850A	Po=4.5 typ. mW @ 9mA / WLP=850nm	3,000 units
QBLP676E-V940A	QBLP676E-V940A	Po=6 typ. mW @ 9mA / WLP=940nm	3,000 units

Revision History

Description:	Revision #	Revision Date
New Release of QBLP676E-VXXXXA	V1.0	02/23/2021

Disclaimer

QT-BRIGHTTEK reserves the right to make changes without further notice to any products herein to improve reliability, function or design. QT-BRIGHTTEK does not assume any liability arising out of the application or use of any product or circuit described herein; neither does it convey any license under its patent rights, nor the rights of others.

Life Support Policy

QT-BRIGHTTEK's products are not authorized for use as critical components in life support devices or systems without the express written approval of QT-BRIGHTTEK. As used herein:

1. Life support devices or systems are devices or systems which, (a) are intended for surgical implant into the body, or (b) support or sustain life, and (c) whose failure to perform when properly used in accordance with instructions for use provided in the labeling, can be reasonably expected to result in a significant injury of the user.
2. A critical component in any component of a life support device or system whose failure to perform can be reasonably expected to cause the failure of the life support device or system, or to affect its safety or effectiveness.