

QT-Brightek SMD Display Series

0.39" Single Digit Display

Part No.: QBSS39ZXX

XX= Color

Z= 1: Common Cathode

Z = 0: Common Anode

Table of Contents:

Introduction	3
Electrical / Optical Characteristic: (Ta=25 °C)	4
Absolute Maximum Rating	4
Pin Configuration	5
Characteristic Curves.....	6
Solder Profile & Footprint.....	8
Packing & Labeling	9
Ordering Information	10
Revision History	11
Disclaimer	11

Electrical / Optical Characteristic: (Ta=25 °C)

Product		Material	Color	I _F (mA)	V _F (V)		λ _d (nm)			I _V (mcd)
CC	CA				Typ.	Max.	Min.	Typ.	Max.	Typ.
QBSS391R	QBSS390R	AllnGaP	Red	20	2.0	2.6	--	624	--	38
QBSS391S	QBSS390S	AllnGaP	Deep Red	20	2.0	2.6	--	640	--	10
QBSS391Y	QBSS390Y	AllnGaP	Yellow	20	2.0	2.6	--	590	--	30
QBSS391O	QBSS390O	AllnGaP	Orange	20	2.0	2.6	--	610	--	30
QBSS391AG	QBSS390AG	AllnGaP	Yellow Green	20	2.0	2.6	--	571	--	15
QBSS391IG	QBSS390IG	InGaN	True Green	20	3.2	4.0	--	525	--	130
QBSS391IB	QBSS390IB	InGaN	Blue	20	3.2	4.0	--	470	--	40

Absolute Maximum Rating

Material	P _d (mW)	Derating linear from 25°C per dice (mA/°C)	I _F (mA)	I _{PF} (mA)*	V _R (V)	T _{OP} (°C)	T _{ST} (°C)	T _{SOL} (°C)**
AllnGaP	70	0.28	25	90	5	-40 to +105	-40 to +105	260
InGaN	120	0.3	30	100	5	-40 to +105	-40 to +105	260

*Duty 1/10 @ 1KHz

**IR Reflow for no more than 5 sec @ 260 °C

Pin Configuration

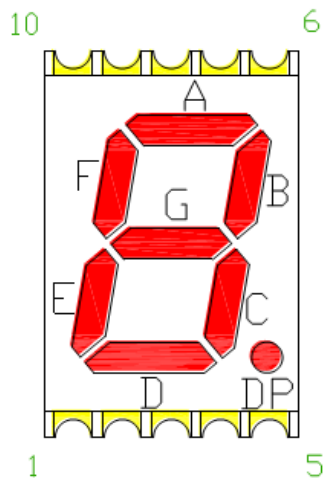

CC	CA
<p style="text-align: center;">3,8</p> <p style="text-align: center;">A B C D E F G DP 7 6 4 2 1 9 10 5</p>	<p style="text-align: center;">3,8</p> <p style="text-align: center;">A B C D E F G DP 7 6 4 2 1 9 10 5</p>

Characteristic Curves

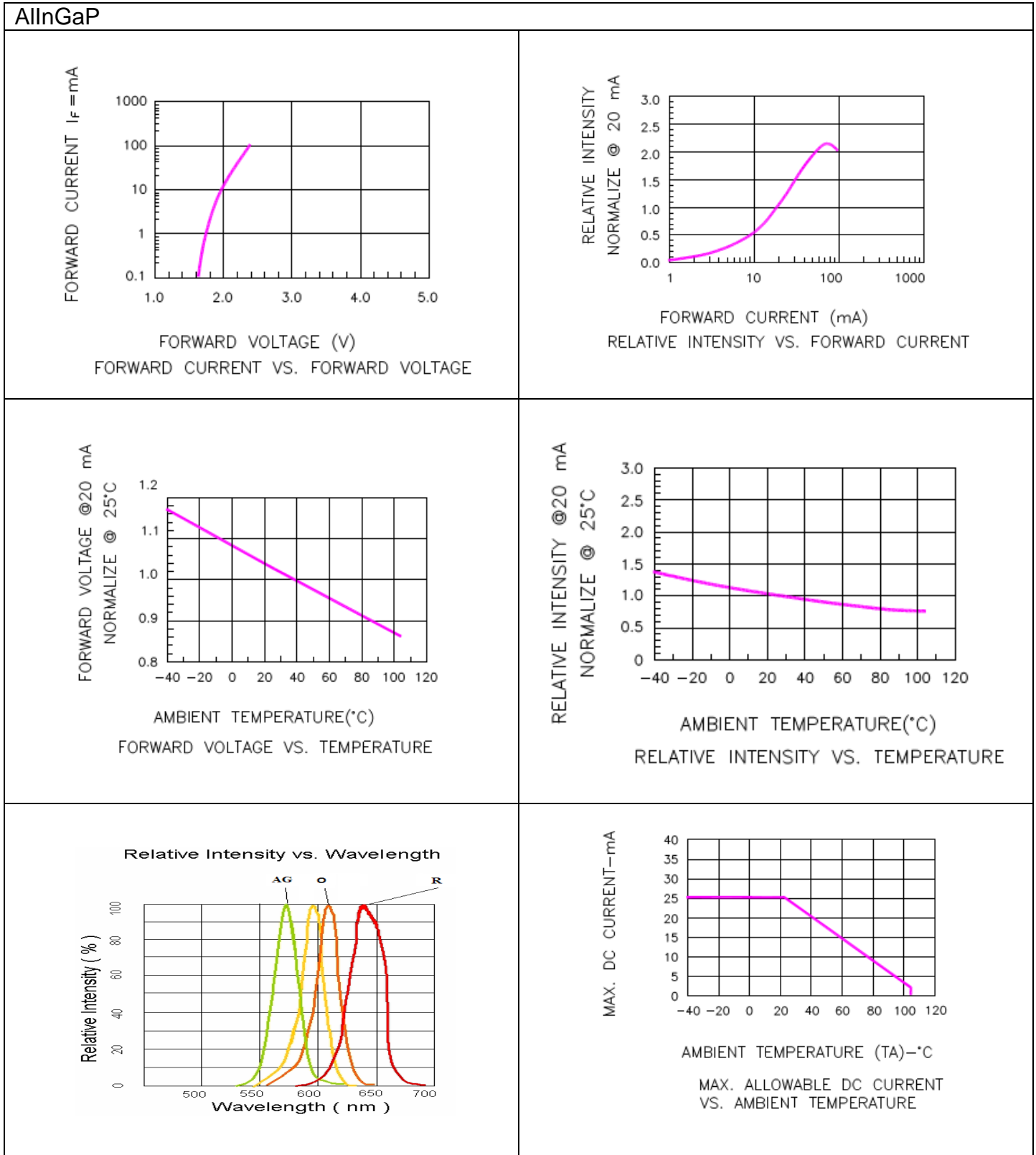

InGaN

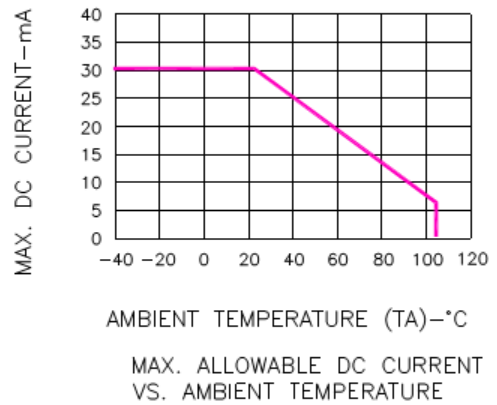
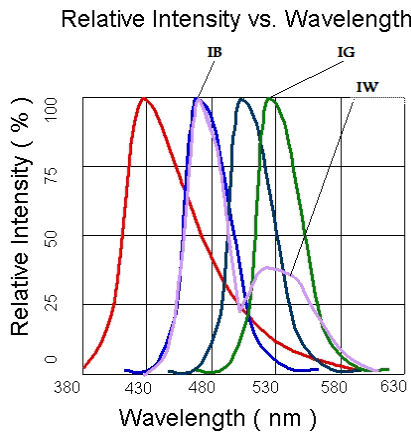
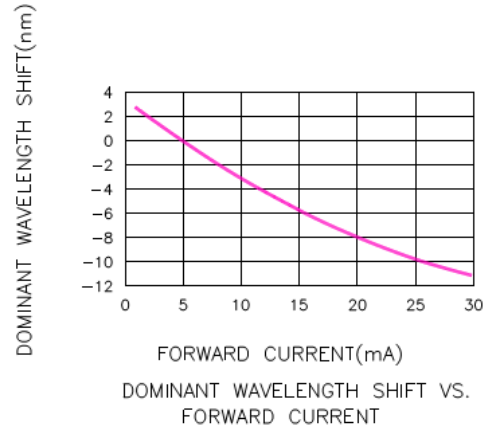
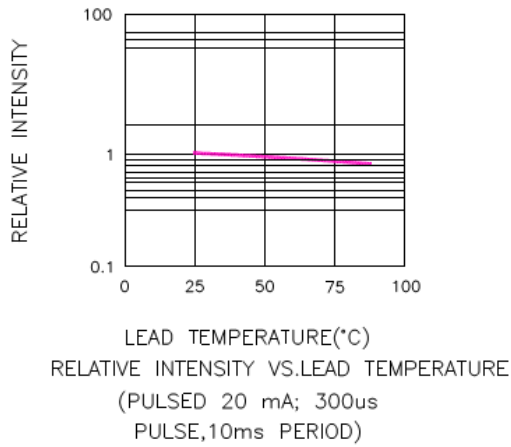
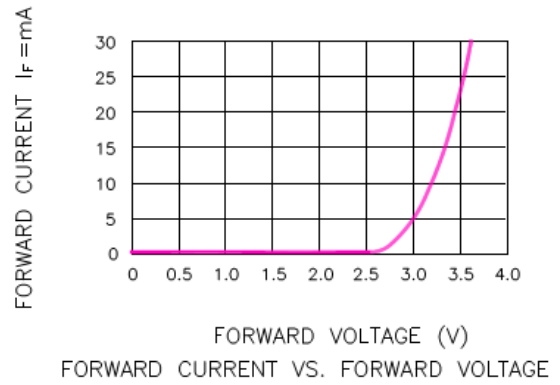
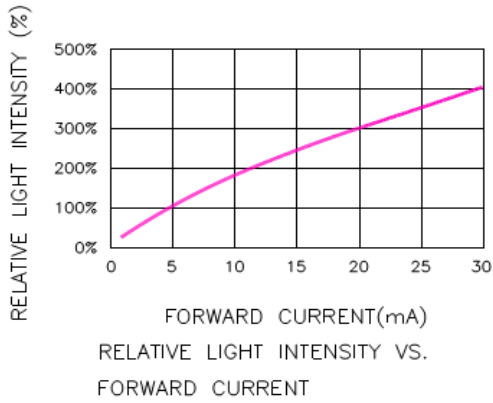

Solder Profile & Footprint

Pb free reflow soldering Profile

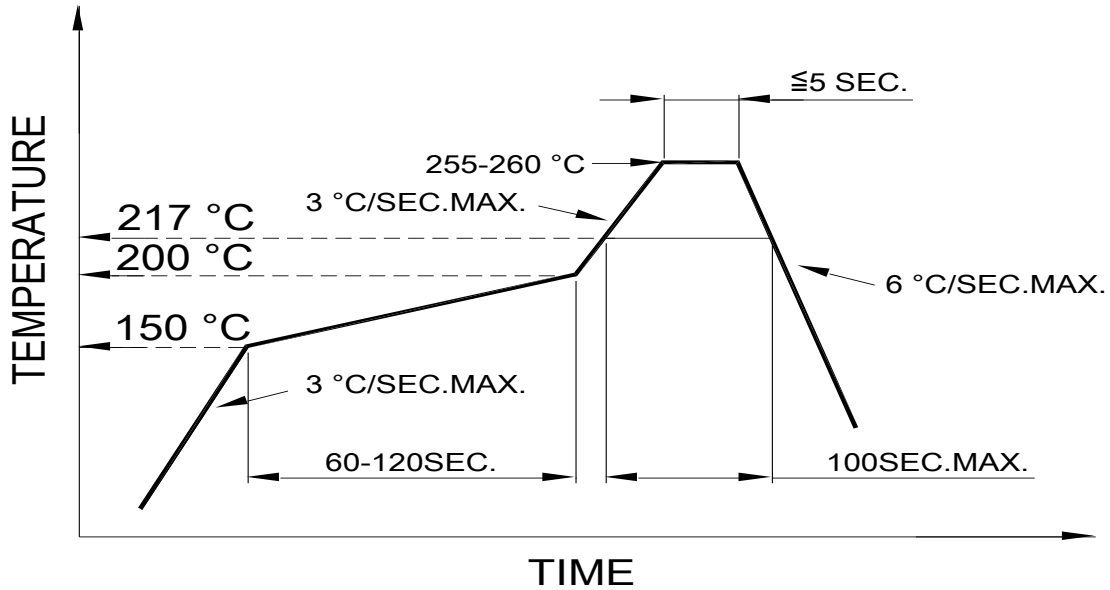

Recommended Pad Layout

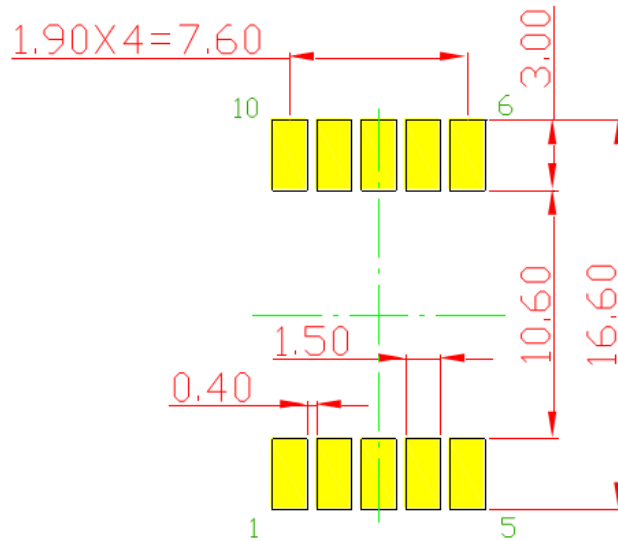

Units: mm

Tolerance: ±0.25mm

Packing & Labeling

Reel Dimensions:

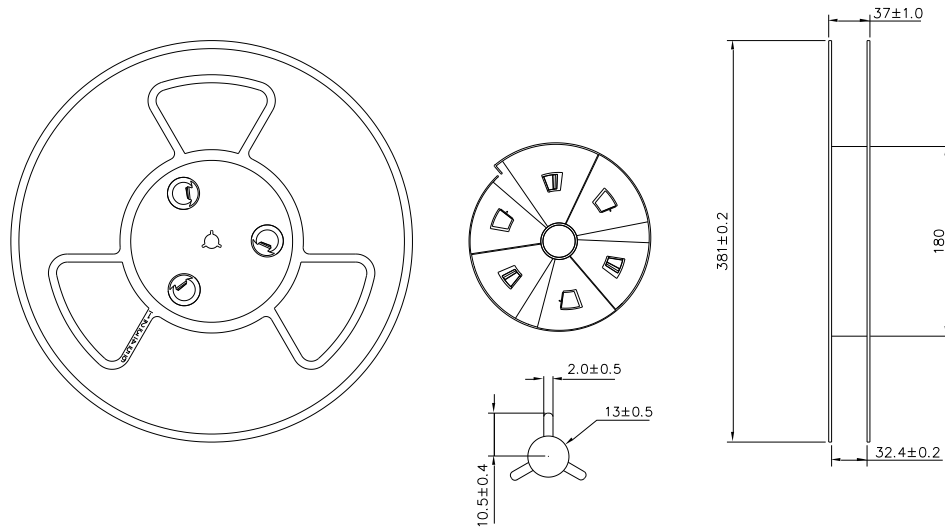

Unit: mm

Packing Method:

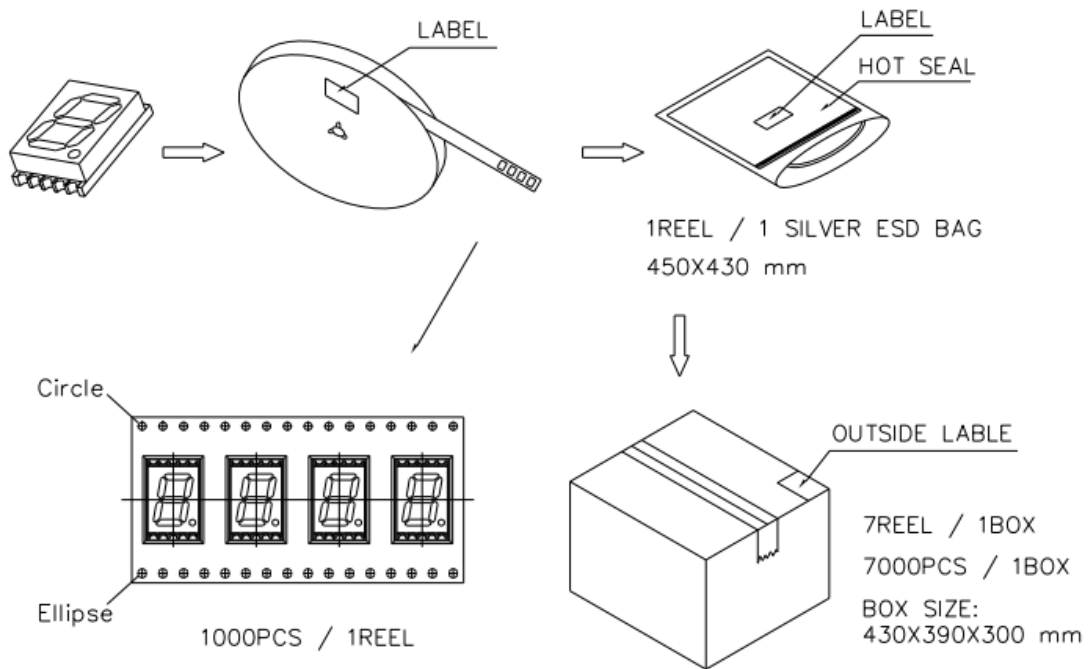

Ordering Information

Product		Orderable Part #		Spec Range	Quantity per Reel
CC	CA	CC	CA		
QBSS391R	QBSS390R	QBSS391R	QBSS390R	Iv=38mcd typ. @ I _F =20mA / λ _D :624nm typ.	1000
QBSS391S	QBSS390S	QBSS391S	QBSS390S	Iv=10mcd typ. @ I _F =20mA / λ _D :640nm typ.	1000
QBSS391Y	QBSS390Y	QBSS391Y	QBSS390Y	Iv=30mcd typ. @ I _F =20mA / λ _D :590nm typ.	1000
QBSS391O	QBSS390O	QBSS391O	QBSS390O	Iv=30mcd typ. @ I _F =20mA / λ _D :610nm typ.	1000
QBSS391AG	QBSS390AG	QBSS391AG	QBSS390AG	Iv=15mcd typ. @ I _F =20mA / λ _D :571nm typ.	1000
QBSS391IG	QBSS390IG	QBSS391IG	QBSS390IG	Iv=130mcd typ. @ I _F =20mA / λ _D :525nm typ.	1000
QBSS391IB	QBSS390IB	QBSS391IB	QBSS390IB	Iv=40mcd typ. @ I _F =20mA / λ _D :470nm typ.	1000

Revision History

Description:	Revision #	Revision Date
New Release of QBSS39ZXX	V1.0	06/24/2011
Amend the optical spec / Add packing spec	V1.1	01/20/2014
Update spec (typ. brightness) and typo on p/ns	V1.2	08/27/2015
Remove white color from the series	V1.3	10/29/2015

Disclaimer

QT-BRIGHTTEK reserves the right to make changes without further notice to any products herein to improve reliability, function or design. QT-BRIGHTTEK does not assume any liability arising out of the application or use of any product or circuit described herein; neither does it convey any license under its patent rights, nor the rights of others.

Life Support Policy

QT-BRIGHTTEK's products are not authorized for use as critical components in life support devices or systems without the express written approval of QT-BRIGHTTEK. As used herein:

1. Life support devices or systems are devices or systems which, (a) are intended for surgical implant into the body, or (b) support or sustain life, and (c) whose failure to perform when properly used in accordance with instructions for use provided in the labeling, can be reasonably expected to result in a significant injury of the user.
2. A critical component in any component of a life support device or system whose failure to perform can be reasonably expected to cause the failure of the life support device or system, or to affect its safety or effectiveness.